

YAO HAN

手提式縫口袋機

MODEL

N600A (ONE THREAD)
單線

N602A (TWO THREAD)
雙線

N600H (ONE THREAD, HIGH SPEED)
單線, 高速

N602H (TWO THREAD, HIGH SPEED)
雙線, 高速

PORTABLE BAG CLOSER

PARTS BOOK 零件本

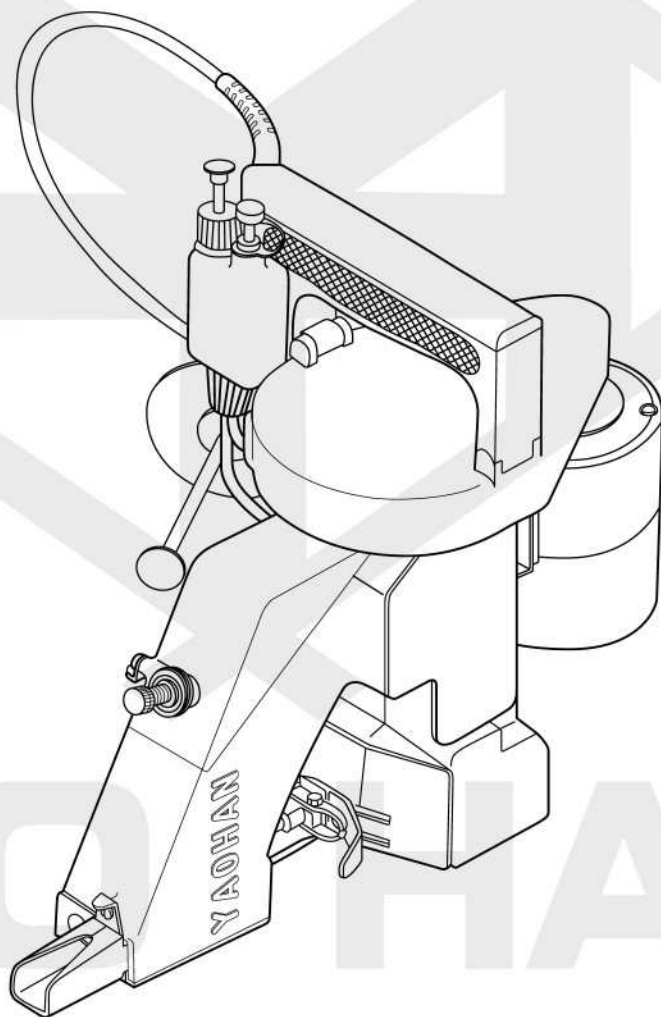

耀瀚股份有限公司
YAO HAN INDUSTRIES CO., LTD.

ORDERING PARTS

The parts list showing all the parts used in the machine is included in this book.

Check the list, and specify parts numbers and quantities required clearly.

Send your order to the nearest agent, distributor or one of our branch offices.

1. Description of each part and its stamp number is described in this parts list. Screws and nuts for parts are shown adjacent to the relevant parts. When ordering parts, describe clearly stamp number with its name of part.
2. The parts which have no Ref. Number can not be delivered independently; always order it as an assembly.
3. A set of assembled parts is represented by the stamp number of its main parts.
4. The last figure in the parts stamp number advances on each improvement of the parts.

*The part list is subject to change without prior notice.

訂購零件須知：

機器裡所有零件，皆已列在零件本上。

如果有需要訂購零件，請告知我們零件號碼及所需數量，並注意下列事項：

1. 每一個零件都有特定的號碼及品名，訂購時請依零件號碼訂購。
2. 若有零件標示在零件本上但是卻沒有號碼或品名，這代表他是整組販售，不零賣。
3. 整組販售的零件，零件上標明的號碼是整組的零件號碼。

CONTENTS

(1) THREAD TENSION AND COVER PARTS.....	10
(2) BUSHINGS, OILINGS AND HANDLE PARTS.....	12
(3) NEEDLE BAR, PRESSER BAR AND DRIVING PARTS.....	14
(4) LOOPER DRIVING PARTS.....	16
(5) FEED DRIVING AND THREAD CUTTER PARTS.....	18
(6) MOTOR PARTS (For Totally Enclosed Type Motor).....	20
(8) CRAPE TAPE BINDING AND CUTTER PARTS (Special Order Parts).....	24
(9) N602A, N602H THREAD STAND AND THREAD TENSION PARTS.....	26
(10) N602A, N602H FEED DRIVING AND THREAD CUTTER PARTS.....	28
(11) MN600A, MN602A PARTS	30
(12) FN600A, FN602A PARTS	32
(13) ACCESSORY BAG PARTS	34
(14) MOTOR PARTS	36

(1) THRED TENSION AND COVER PARTS

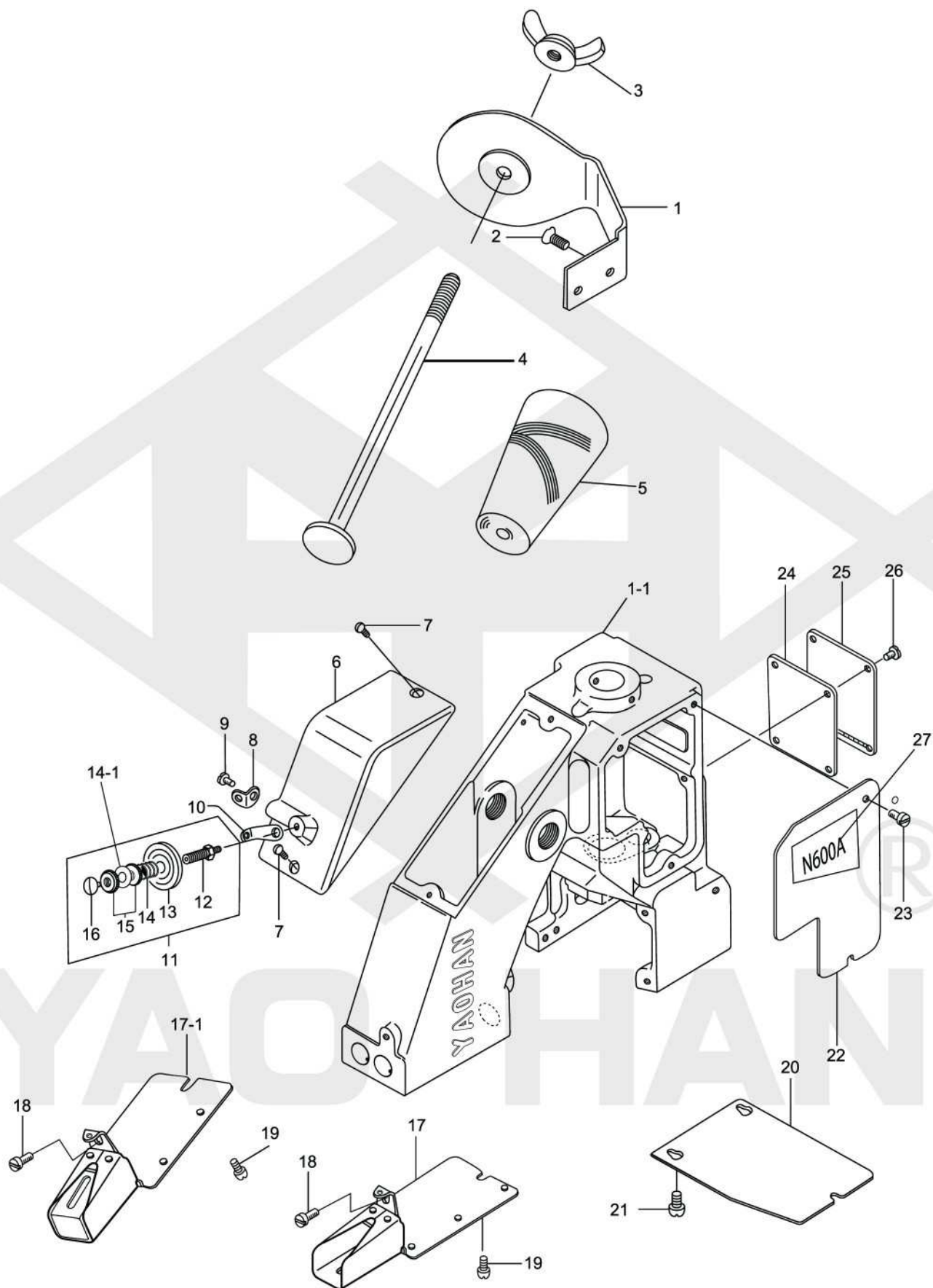

(1) THRED TENSION AND COVER PARTS

ITEM	PART NO.	DESCRIPTION	Q'ty	REMARKS
1	6001001	THREAD STAND	線架	1
1-1	6001001-1	MAIN FRAME	本體	
2	6001002	SCREW, FOR 6001001	螺絲	2
3	3001641	NUT, FOR 6001004, FOR YAO HAN ONLY	蝴蝶螺帽	2
4	3001634	THREAD CONE CLAMPING ROD, FOR YAO HAN ONLY	線柱	1
5	6001005	THREAD	線	1
6	6001006	TOP COVER	機台三角蓋	1
7	6001007	SCREW, FOR 6001006	螺絲	2
8	6001008	THREAD EYELET	穿線孔架	1
9	6001009	SCREW, FOR 6001008	螺絲	1
10	6001010	THREAD TENSION EYELET	沙拉組過線	1
11	6001011	THREAD TENSION ASSEMBLY	沙拉組	1
12	6001012	TENSION POST	沙拉組軸	1
13	6001013	TENSION DISC	壓線盤	2
14	6001014	TENSION SPRING	彈簧	1
14-1	6001014-1	WASHER	華司	
15	6001015	TENSION NUT	調整螺帽	1
16	6001016	SCREW, FOR 6001011	螺絲	2
17	6001017	NEEDLE BAR GUARD	針棒護板	1
17-1	6001017-1	NEEDLE BAR GUARD FOR "CE" TYPE	針棒護板(CE)	1
18	6001009	SCREW, FOR 6001017	螺絲	1
19	6001023	SCREW, FOR 6001017	螺絲	1
20	6001020	LOOPER COVER	彎針蓋板	2
21	6001019	SCREW, FOR 6001020	螺絲	1
22	6001022	SLIDE PLATE	側面板	3
23	6001023	SCREW, FOR 6001022	螺絲	1
24	6001024	GASKET	防油墊片	3
25	6001025	INSIDE COVER	蓋板	1
26	6001023	SCREW, FOR 6001025	螺絲	1
27	6001027	NAMEPLATE	N600A鋁牌(黑底)	1

(2) BUSHINGS, OILINGS AND HANDLE PARTS

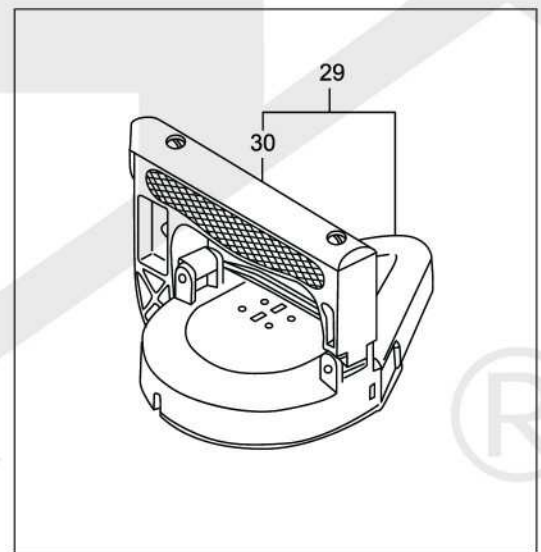
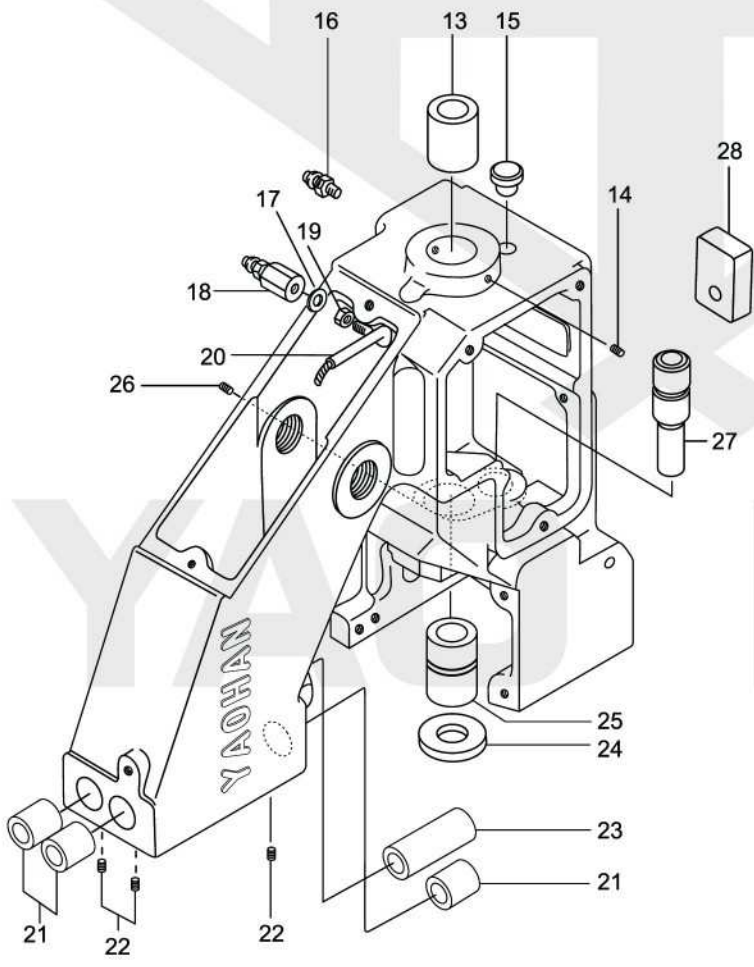
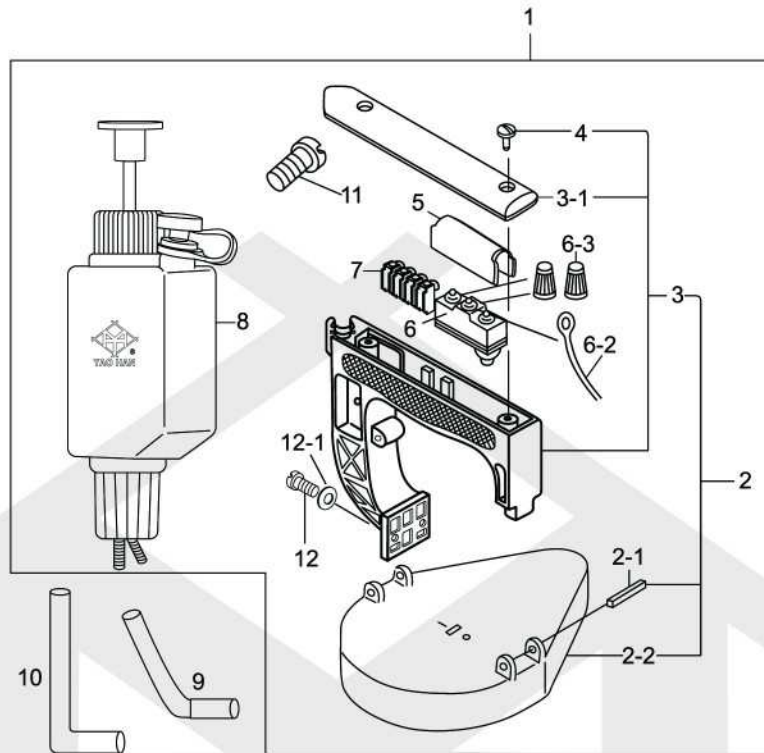

(2) BUSHINGS, OILINGS AND HANDLE PARTS

ITEM	PART NO.	DESCRIPTION	Q'ty	REMARKS
1	6001201	HANDLE ASSEMBLY WITH OILER SWITCH	1	
2	6001202	HANDLE ASSEMBLY	1	
2-1	6001202-1	PIN	2	
2-2	6001202-2	COVER	1	
3	6001203	HANDLE	1	
3-1	6001203-1	COVER HANDLE	1	
4	6001016	SCREW, FOR 6001202	2	
5	6001205	MICRO SWITCH COVER CE	1	
6	6001206	MICRO SWITCH (Z-15GK655-B)	1	
6-2	6001206-2	END PLUG WIRE	1	
6-3	6001206-3	NUT WIRE	2	
7	6001207	FLEXIBLE TERMINAL BLOCK (ML-S-1, 4P) CE	1	
8	6001208N	OILER	1	
9	6001209	OIL TUBE, WITH OIL FELT (ϕ 6x95 L)	1	
10	6001210	OIL TUBE, WITH OIL FELT (ϕ 6x100 L)	1	
11	6001430	SCREW, FOR 6001208	1	
12	6001212	SCREW, FOR 6001202S	2	
12-1	6001212-1	WASHER	2	
13	6001213	MAIN SHAFT BUSHING, REAR	1	
14	6001214	SCREW, FOR 6001213	1	
15	6001215	RUBBER BUSHING	1	
16	6001216	JOINT	2	
17	6001217	WASHER	1	
18	6001218	JOINT	1	
19	6001219	NUT	1	
20	6001220	OIL PIPE	3	
21	6001221	BUSHING FOR PRESSER BAR NEEDLE BAR, UPPER	3	
22	6001222	SCREW, FOR 6001221	5	
23	6001223	PRESSER BAR BUSHING, LOWER	1	
24	6001224	OIL FELT	1	
25	6001225	MAIN SHAFT BUSHING, REAR	1	
26	6001222	SCREW, FOR 6001225	1	
27	6001227	LOOPER ROCKER SHAFT BUSHING	1	
28	6001228	OIL FELT	(1)	
29	6001229	HANDLE ASSEMBLY AND SWITCH	(1)	
30	6001230	HANDLE AND SWITCH		

(3) NEEDLE BAR, PRESSER BAR AND DRIVING PARTS

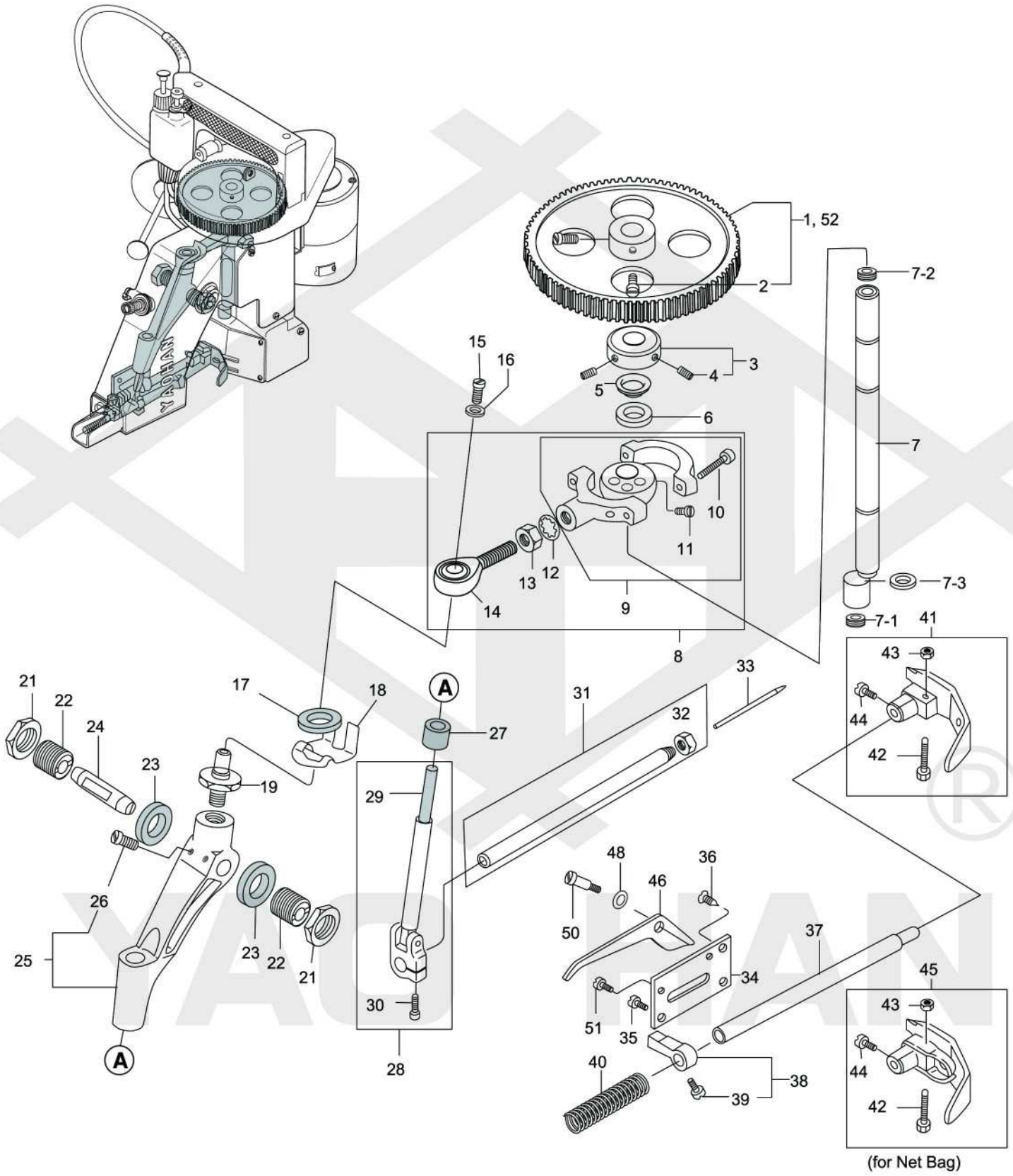

(3) NEEDLE BAR, PRESSER BAR AND DRIVING PARTS

ITEM	PART NO.	DESCRIPTION	Q'ty	REMARKS
1	6001401	SYNCHRO PULLEY (70 TEETH) FOR N600A,N602A	1	
2	6001402	SCREW, FOR 6001401	2	
3	6001403	RETAINING COLLAR	1	
4	6001404	SCREW, FOR 6001403	2	
5	6001405	SPACER	1	
6	6001224	OIL FELT	1	
7	6001407	MAIN SHAFT	1	
7-1	6001407-1	SCREW	1	
7-2	6001407-2	SCREW	1	
7-3	6001407-3	OIL FELT	1	
8	6001408	CONNECTING ROD ASSEMBLY	1	
9	6001409	CONNECTING ROD SUB-ASSEMBLY	1	
10	6001410	SCREW, FOR CONNECTING ROD CAP	2	
11	6001411	SCREW, FOR ECCENTRIC CAM	1	
12	6001412	WASHER, FOR 6001408	1	
13	6001413	NUT, FOR 6001408 (A-8-S)	1	
14	6001414	ROD END (POS-8)	1	
15	6001415	SCREW, FOR 6001419	1	
16	6001416	WASHER, FOR 6001419	1	
17	6001417	OIL FELT	1	
18	6001418	SPRING	1	
19	6001419	ROD END STUD	2	
21	6001421	NUT, FOR 6001422	2	
22	6001422	ADJUSTING STUD	2	
23	6001423	OIL FELT	2	
24	6001424	NEEDLE BAR LEVER STUD	1	
25	6001425	NEEDLE BAR LEVER ASSEMBLY	2	
26	6001426	SCREW, FOR 6001425	1	
27	6001427	OIL FELT	1	
28	6001428	NEEDLE BAR CONNECTION ASSEMBLY	1	
29	6001429	OIL TUBE	1	
30	6001430	SCREW, FOR 6001428	1	
31	6001431	NEEDLE BAR WITH NUT	1	
32	6001432	NEEDLE CLAMP NUT	1	
33	6001433	NEEDLE (DNX1 #25)	1	
34	6001434	PRESSER FOOT LIFTER BASE	1	
35	6001435	SCREW, FOR 6001434	2	
36	6001436	SCREW, FOR 6001434	1	
37	6001437	PRESSER BAR	1	
38	6001438	PRESSER BAR CONNECTION	1	
39	6001430	SCREW, FOR 6001438	1	
40	6001440	PRESSER SPRING	1	
41	6001441	PRESSER FOOT ASSEMBLY	1	
42	6001442	SCREW	1	
43	6001443	NUT SM 9/64"-40	1	
44	6001444	SCREW, FOR 6001441, 6001445	1	
45	6001445	PRESSER FOOT ASSEMBLY (FOR CE)	(1)	
46	6001446	PRESSER FOOT LIFTER	(1)	
48	6001448	"O" RING	(1)	
50	6001450	SCREW, FOR 6001446	(1)	
51	6001451	SCREW, FOR LIFTER STOPPER	(1)	
52	6001452	SYNCHRO PULLEY (60 TEETH) FOR N600H,N602H	(1)	

(4) LOOPER DRIVING PARTS

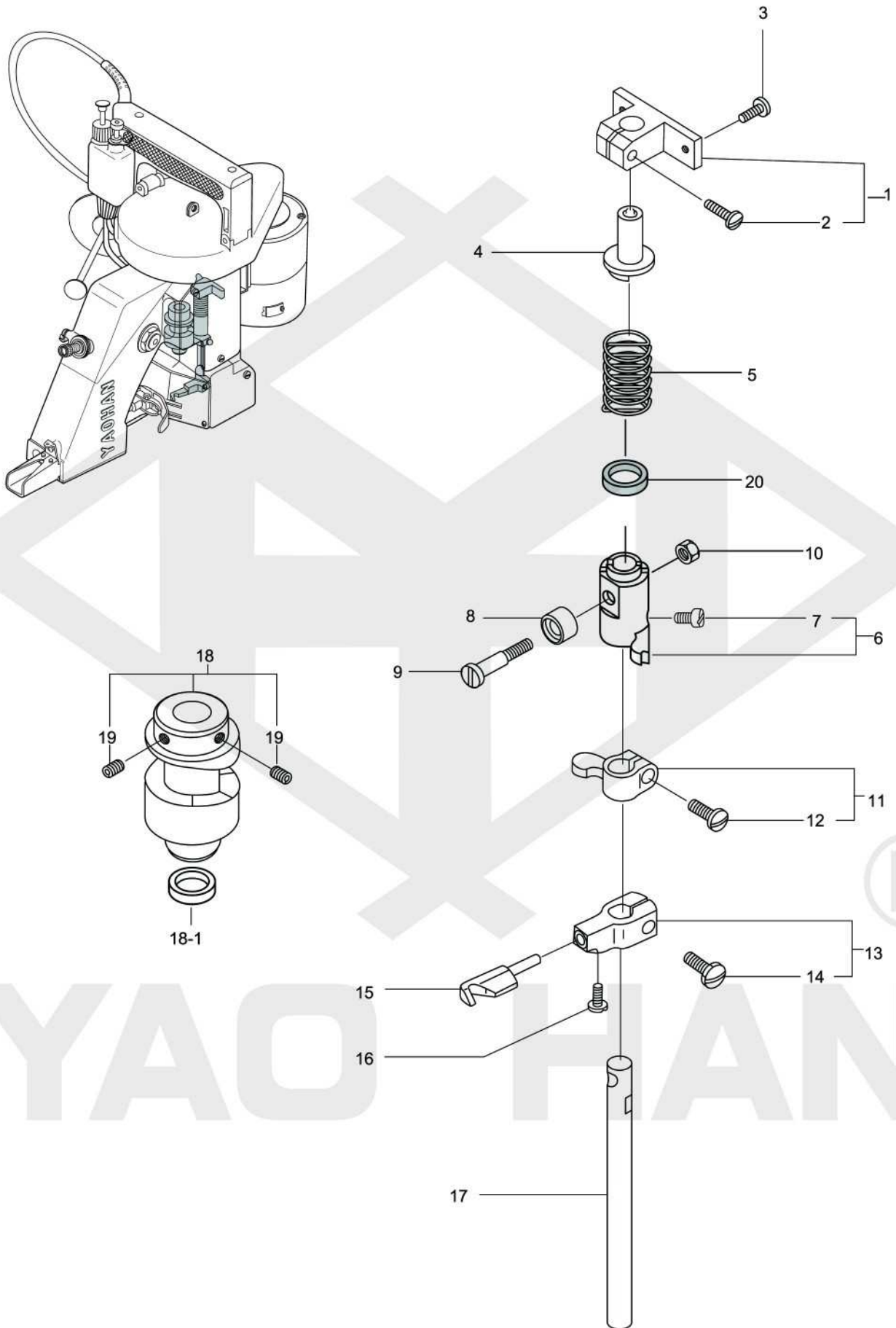

(4) LOOPER DRIVING PARTS

ITEM	PART NO.	DESCRIPTION	Q'ty	REMARKS
1	6001601	SPRING SUPPORTER BLOCK	1	(2)
2	6001602	SCREW, FOR 6001601	1	
3	6001023	SCREW, FOR 6001601	2	
4	6001604	SPRING SUPPORTER	1	
5	6001605	SPRING	1	
6	6001606	LOOPER ROCKER SHAFT ARM (A)	1	(7)
7	6001435	SCREW, FOR 6001606	1	
8	6001608	ROLLER	1	
9	6001609	ROLLER STUD SCREW	1	
10	6001610	NUT, FOR 6001609	1	
11	6001611	LOOPER ROCKER SHAFT ARM (B)	1	(12)
12	6001612	SCREW, FOR 6001611	1	
13	6001613	LOOPER ROCKER	1	
14	6001415	SCREW, FOR 6001613	1	(14)
15	6001615	LOOPER	1	
16	6001451	SCREW, FOR 6001415	1	
17	6001617	LOOPER ROCKER SHAFT	1	
18	6001618	LOOPER DRIVE CAM	1	(19)
18-1	6001618-1	WASHER	2	
19	6001619	SCREW, FOR 6001618	2	
20	6001224	OIL FELT	1	

(5) FEED DRIVING AND THREAD CUTTER PARTS

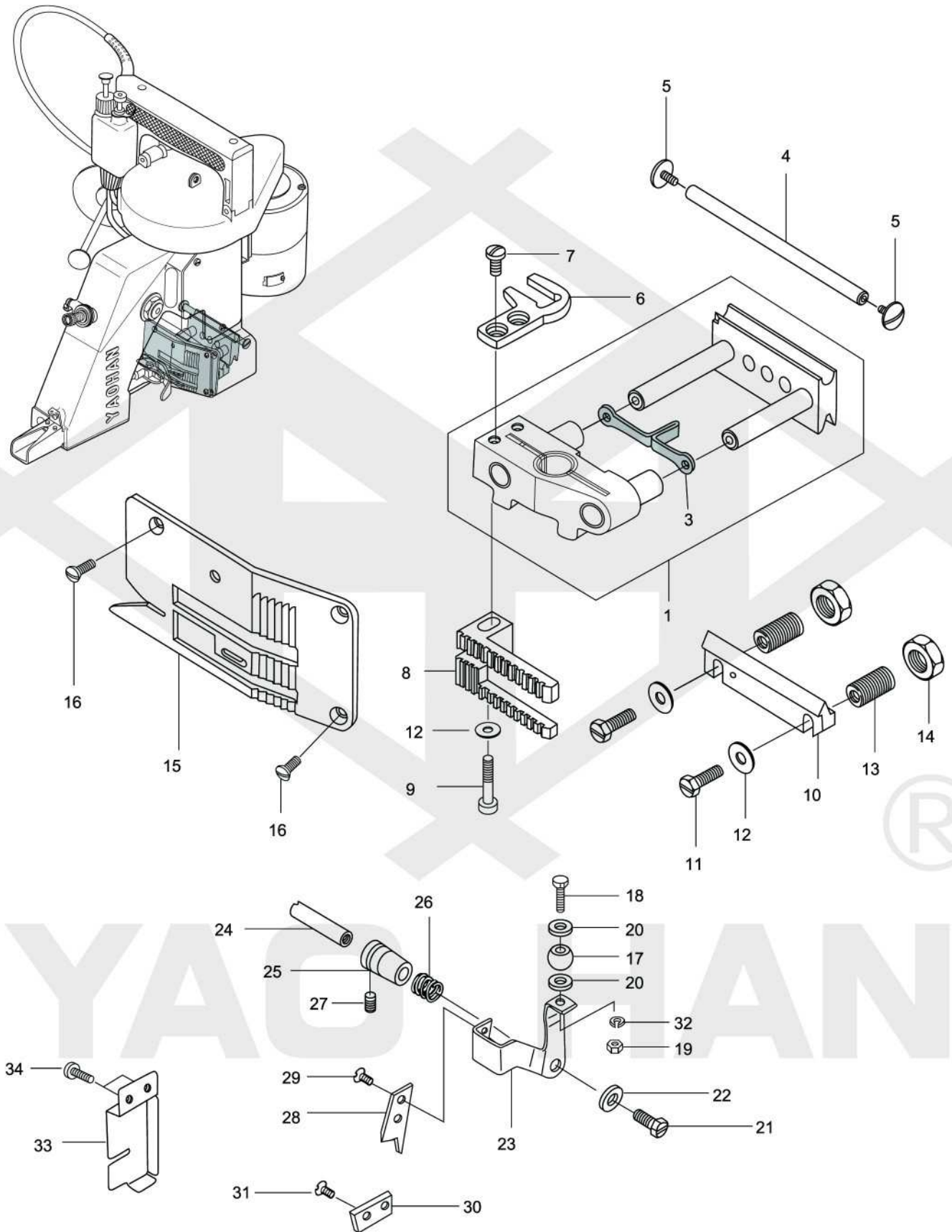

(5) FEED DRIVING AND THREAD CUTTER PARTS

ITEM	PART NO.	DESCRIPTION	Q'ty	REMARKS
1	6001801	FEED DOG CARRIER BLOCK ASSEMBLY	1	(2,3)
3	6001803	OIL FELT	1	
4	6001804	SLIDE BLOCK GUIDE STUD	1	
5	6001016	SCREW, FOR 6001804	2	
6	6001806	KNIFE BRACKET EXTENSION	1	
7	6001807	SCREW, FOR 6001806	2	
8	6001808	FEED DOG	1	
9	6001809	SCREW, FOR 6001808	1	
10	6001810	SLIDE BLOCK ADJUSTING	1	
11	6001811	LOCK BOLT, FOR 6001813	2	
12	6001416	WASHER, FOR 6001813	3	
13	6001813	STUD SLIDE BLOCK ADJUSTING SUPPORT	2	
14	6001814	LOCK NUT, FOR 6001813	2	
15	6001815	THROAT PLATE	1	
16	6001007	SCREW, FOR 6001815	3	
17	6001817	BALL	1	
18	6001818	BOLT, FOR 6001817 (M3X0.5X12 L)	1	
19	6001819	NUT, FOR 6001817 (M3X0.5)	1	
20	6001820	WASHER, FOR 6001817 (M3)	2	
21	6001821	SCREW, FOR 6001823	1	
22	6001416	WASHER, FOR 6001823	1	
23	6001823	KNIFE BRACKET	1	
24	6001824	KNIFE BRACKET PIN	1	
25	6001825	BUSHING, FOR 6001824	1	
26	6001826	KNIFE TENSION SPRING	1	
27	6001222	SCREW, FOR 6001825	1	
28	6001828	KNIFE MOVING	1	
29	6001829	SCREW, 6001828	2	
30	6001830	KNIFE STATIONARY	1	
31	6001829	SCREW, FOR 6001830	2	
32	6001832	SPRING LOCK WASHER (M3)	1	
33	6001833	KNIFE COVER	1	
34	6002017	SCREW, FOR 6001833	2	

(6) MOTOR, PARTS (For Totally Enclosed Type motor)

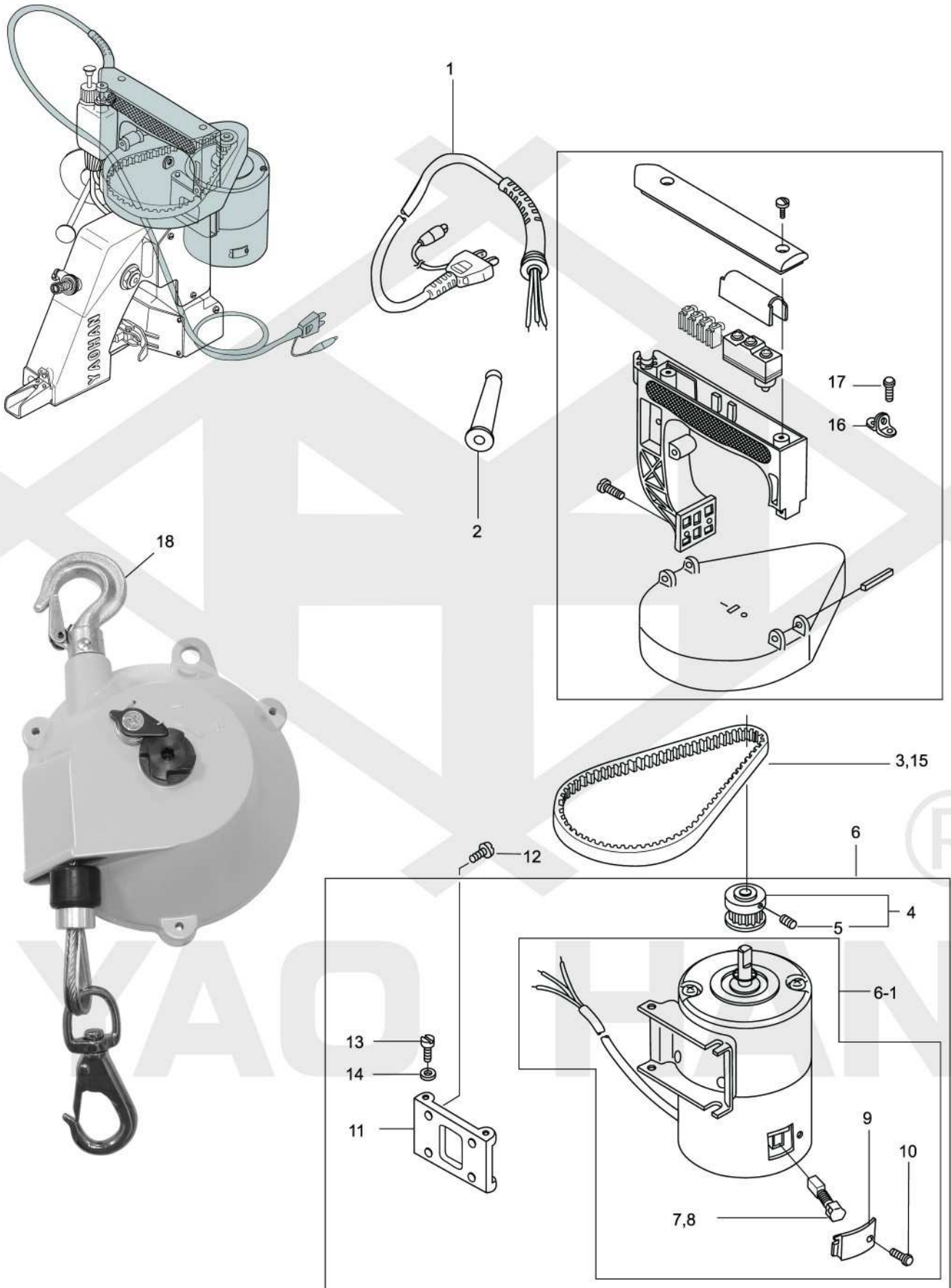

(6) MOTOR, PARTS (For Totally Enclosed Type motor)

ITEM	PART NO.	DESCRIPTION	Q'ty	REMARKS
1	6002001	CABTYER CORD, WITH PLUG (PLANE TYPE) 110V	1	
	6002001-1	CABTYER CORD, WITH PLUG "CE"	1	
	6002001-2	CABTYER CORD, 220V	1	
	6002001-3	CABTYER CORD, WITH PLUG 12V	1	
2	6002002	RUBBER BUSHING	1	
3	6002003	TIMING BELT (160XL FOR N600H & N602H)	1	
4	6002004	MOTOR PULLEY	1	
5	6002005	SCREW, FOR 241083	2	
6	6002006	UNIVERSAL MOTOR ASM.(110V)	1	
	6002006-1	UNIVERSAL MOTOR ASM.(220V)	1	
	6002006-2	UNIVERSAL MOTOR ASM.(240V)	1	
	6002006-3	UNIVERSAL MOTOR ASM.(24V)	1	
	6002006-4	UNIVERSAL MOTOR ASM.(12V)	1	(5)
	6002006-5	UNIVERSAL MOTOR ASM.(110V SMALL)	1	
6-1	6002006M	UNIVERSAL MOTOR (110V)	1	
	6002006-1M	UNIVERSAL MOTOR (220V)	1	
	6002006-2M	UNIVERSAL MOTOR (240V)	1	
	6002006-3M	UNIVERSAL MOTOR (24V)	1	
	6002006-4M	UNIVERSAL MOTOR (12V)	1	(5)
	6002006-5M	UNIVERSAL MOTOR (110V SMALL)	1	
7	6002007	CARBON BRUSH, FOR AC MOTOR (SIZE:6X8X15)	2	(7,9,10)
8	6002008	CARBON BRUSH, FOR DC MOTOR 12V/24V (SIZE:6X8X15)	2	(7,9,10)
9	6002009	CAP	1	(8-10)
10	6002010	SCREW (WITH WASHER)	1	(8-10)
11	6002011-1	MOTOR BASE B FOR N600A & N602A	1	
	6002011-2	MOTOR BASE B FOR N600H & N602H (HIGH SPEED)	1	
12	6001212	SCREW	4	
13	6001415	SCREW	4	
14	6002014	WASHER, FOR MOTOR	4	
15	6002015	TIMING BELT (170XL FOR N600A & N602A)	1	
16	6002016	HANGER HOOK	1	
17	6002017	SCREW, FOR 6002016	2	
* 18	SB-5K	SPRING BALANCE FOR 3-5KGS.	1	
	SB-7K	SPRING BALANCE FOR 5-7KGS.	1	
	SB-9K	SPRING BALANCE FOR 7-9KGS.	1	

* SPECIAL ORDER

(8) CRAPE TAPE BINDING AND CUTTER PART (Special Order Parts)

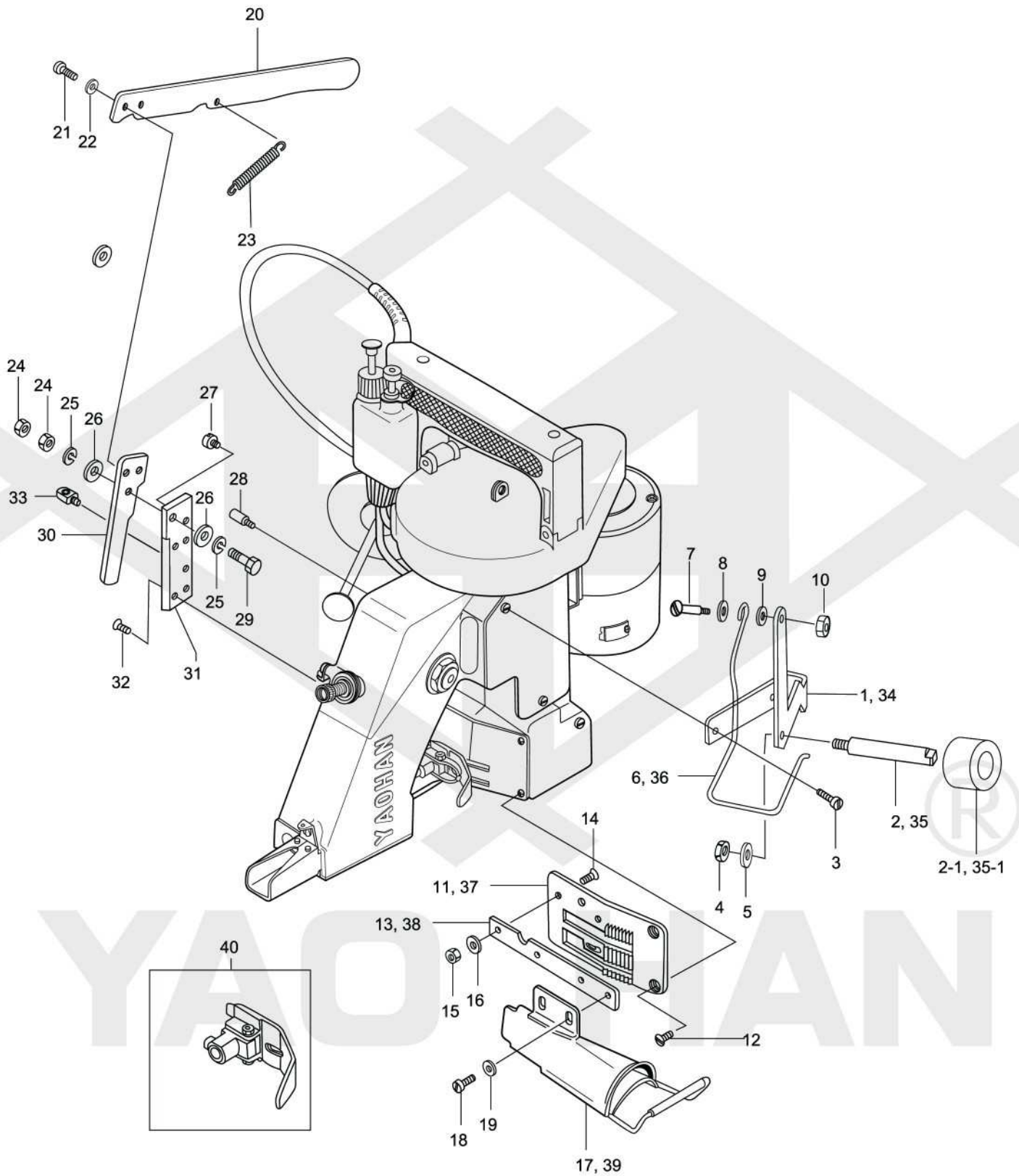

(8) CRAPE TAPE BINDING AND CUTTER PART (Special Order Parts)

ITEM	PART NO.	DESCRIPTION	Q'ty	REMARKS
1	6002401	CRAPE TAPE BRACKET FOR 50MM	1	
2	6002402	CRAPE TAPE HANGER STUD FOR 50MM	1	
2-1	6002402-1	PAPER BANI FOR 50MM	1	
3	6001602	SCREW, FOR 6002401	2	
4	6002404	NUT, FOR 6002402 15/64"-28	1	
5	6002405	WASHER, FOR 6002402 (M6)	1	
6	6002406	CRAPE TAPE SUPPORTER FOR 50MM	1	
7	6001450	SCREW, FOR 6002401	1	
8	6002408	SPRING WASHER, FOR 6002401	1	
9	6002409	WASHER, FOR 6002401	1	
10	6002410	NUT, FOR 6002401	1	
11	6002411	THROAT PLATE ,FOR CRAPE TAPE WIDTH 50MM	1	
12	6001007	SCREW, FOR 6002411	3	
13	6002413	HOLDER,FOR CRAPE TAPE WIDTH 50MM	1	
14	6001007	SCREW, FOR 6002413	2	
15	6001443	NUT, FOR 6002413	2	
16	6002416	WASHER, FOR 6002413 (M4)	2	
17	6002417	CRAPE TAPE BINDER, FOR CRAPE TAPE WIDTH 50MM	1	
18	6002418	SCREW, FOR 6002417	2	
19	6002416	WASHER, FOR 6002417 (M4)	2	
20	6002420	CUTTER LEVER	1	
21	6002421	SCREW, FOR 6002430	2	
22	6002014	WASHER, FOR 6002430	2	
23	6002423	SPRING, FOR 6002420	1	
24	6002404	NUT, FOR 6002429 15/64"-28	2	
25	6002425	SPRING LOCK WASHER, FOR 6002429 (M6)	2	
26	6002405	WASHER, FOR 6002429 (M6)	2	
27	6002427	STOPPER SCREW, FOR 6002430	1	
28	6002428	STOPPER SCREW, FOR 6002420	1	
29	6002429	HINGE PIN	1	
30	6002430	KNIFE, MOVING	1	
31	6002431	KNIFE, SATIONARY	1	
32	6001829	SCREW, FOR 6002431	4	
33	6002433	SPRING HOOK	1	
34	6002434	CRAPE TAPE BRACKET, FOR CRAPE TAPE WIDTH 70MM	(1)	For Crape Tape width 70mm
35	6002435	CRAPE TAPE HANGER STUD, FOR CRAPE TAPE WIDTH 70MM	(1)	
35-1	6002435-1	PAPER BANI, FOR CRAPE TAPE WIDTH 70MM	(1)	
36	6002436	CRAPE TAPE SUPPORTER, FOR CRAPE TAPE WIDTH 70MM	(1)	
37	6002437	THROAT PLATE, FOR CRAPE TAPE WIDTH 70MM	(1)	
38	6002438	HOLDER, FOR CRAPE TAPE BINDER, FOR CRAPE TAPE WIDTH 70MM	(1)	
39	6002439	CRAPE TAPE BINDER, FOR CRAPE TAPE WIDTH 70MM	(1)	
40	6002440	PRESSER FOOT ASSM, FOR CRAPE TAPE WIDTH 70MM	(1)	

(9) THREAD STAND AND THREAD TENSION PARTS FOR N602A N602H

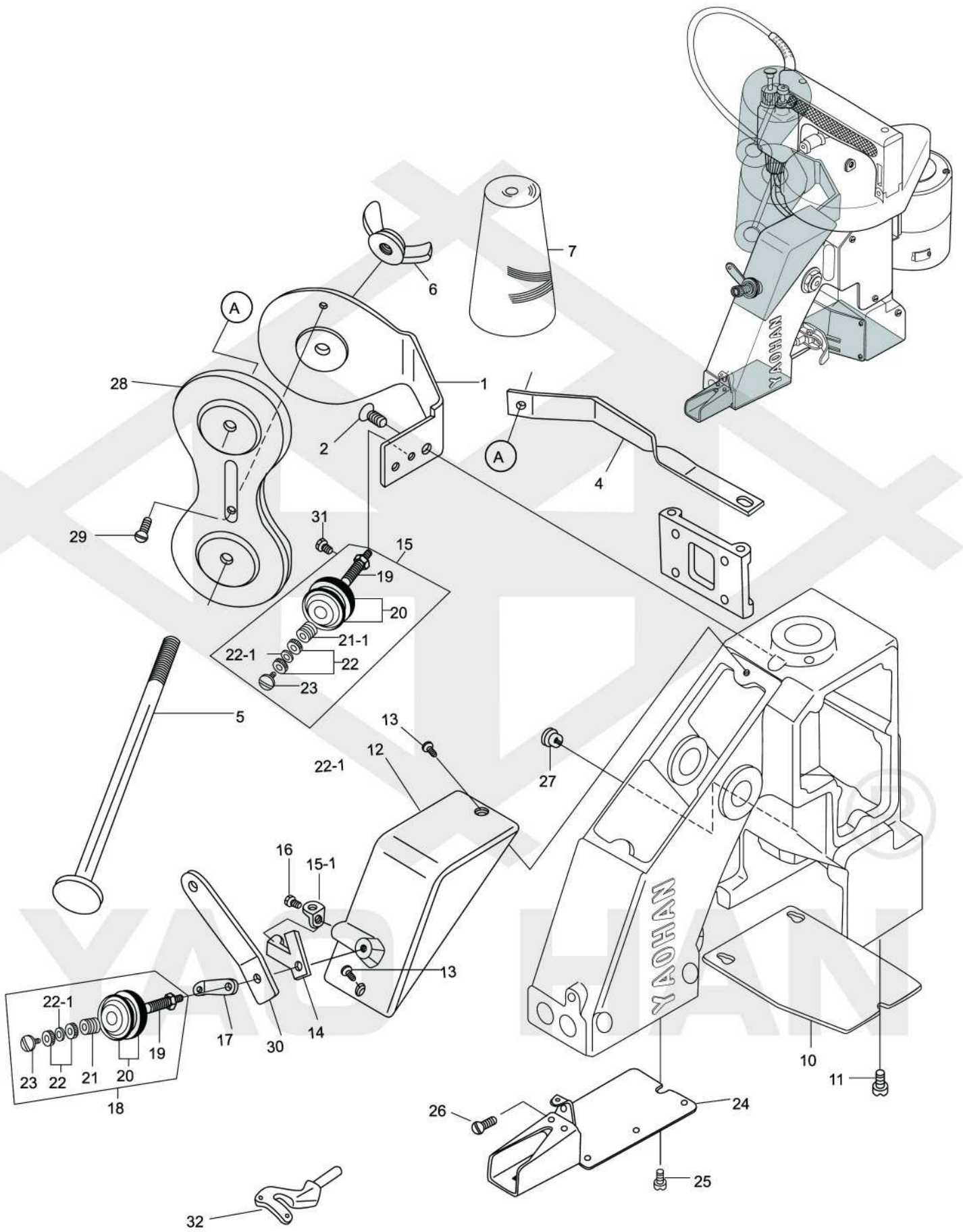

(9) THREAD STAND AND THREAD TENSION PARTS FOR N602A N602H

ITEM	PART NO.	DESCRIPTION	Q'ty	REMARKS
1	6022601-1	THREAD STAND BASE	1	
2	6001002	SCREW, FOR 6001001	2	
4	6022601	SUPPORT FOR TWO THREAD	1	Special Order
5	3001634	THREAD CONE CLAMPING ROD	2	
6	3001641	NUT	2	
7	6001005	THREAD	4	
10	6001020	LOOPER COVER	1	
11	6001019	SCREW, FOR 6001020	3	
12	6001006	TOP COVER	1	
13	6001007	SCREW, FOR 6001006	2	
14	6022602	THREAD EYELET HOLDER FOR TWO THREAD	1	
15	6022615	THREAD TENSION ASSEMBLY	2	(19-23)
15-1	6001008	THREAD EYELET	1	
16	6001009	SCREW, FOR 6001008	1	
17	6001010	THREAD TENSION EYELET	1	
18	6001011	THREAD TENSION ASSEMBLY	1	
19	6001012	TENSION POST	1	
20	6001013	TENSION DISC	2	
21	6001014	TENSION SPRING	1	
21-1	6002621-1	TENSION SPRING	2	
22	6001015	TENSION NUT	1	
22-1	6002622-1	WASHER	1	
23	6001016	SCREW, FOR 6001011	1	
24	6001017	NEEDLE BAR GUARD	2	
25	6001023	SCREW, FOR 6001017	2	
26	6001009	SCREW, FOR 6001017	1	
27	6022603	THREAD GUIDE BUSHING FOR TWO THREAD	1	
28	6022604	THREAD STAND FOR TWO THREAD	1	
29	6001402	SCREW, FOR 6022604	1	
30	6022606	THREAD EYELET FOR TWO THREAD	1	
31	6001009	SCREW, FOR 6001008	1	
32	6022607	LOOPER FOR TWO THREAD	1	

(10) FEED DRIVING AND THREAD CUTTER PARTS FOR N602A N602H

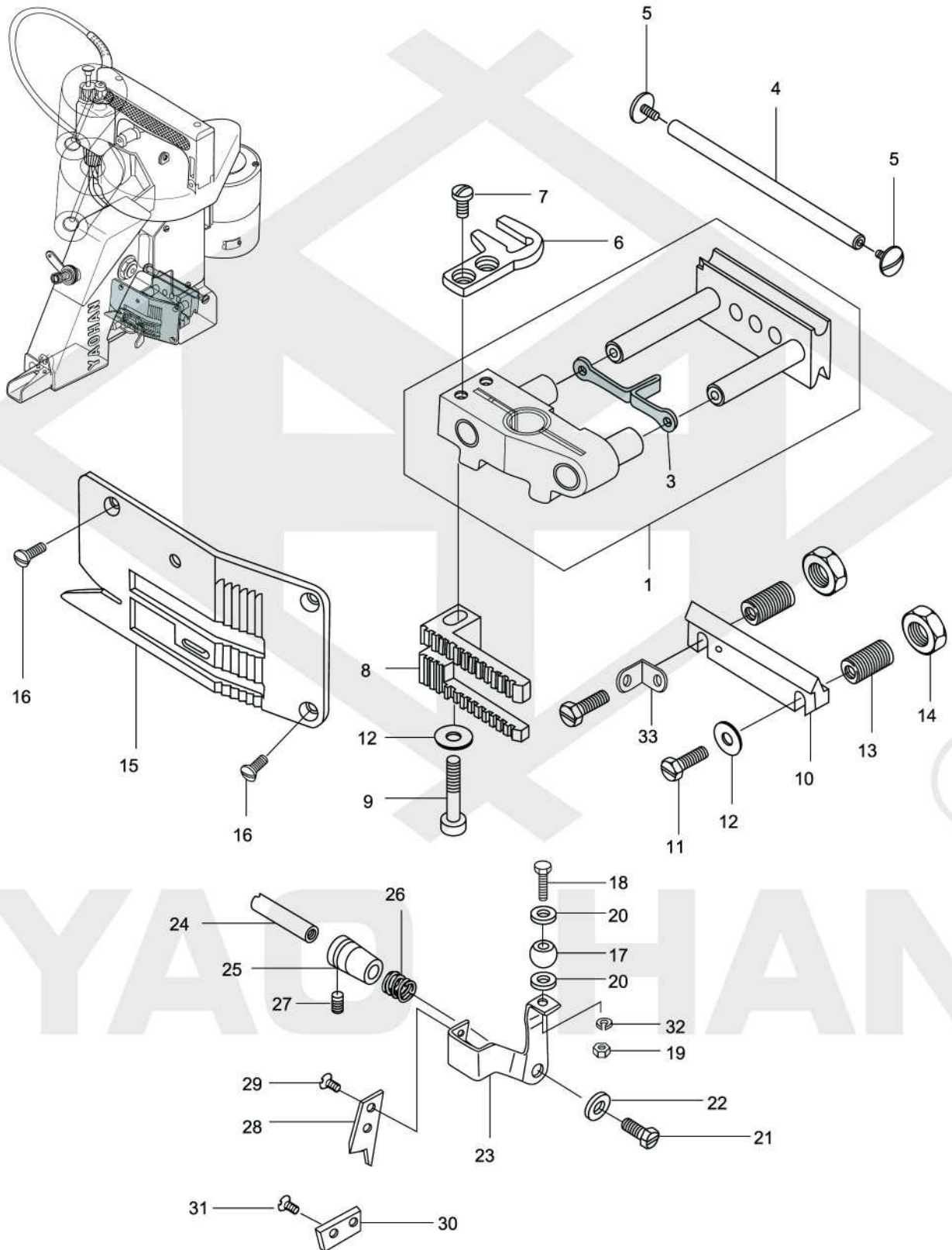

(10) FEED DRIVING AND THREAD CUTTER PARTS FOR N602A N602H

ITEM	PART NO.	DESCRIPTION	Q'ty	REMARKS
1	6203812	FEED DOG CARRIER BLOCK ASSEMBLY	1	(2,3)
3	6001803	OIL FELT	1	
4	6001804	SLIDE BLOCK GUIDE STUD	1	
5	6001016	SCREW, FOR 6001804	2	
6	6001806	KNIFE BRACKET EXTENSION	1	
7	6001807	SCREW, FOR 6001806	2	
8	6022801	FEED DOG FOR TWO THREAD	1	
9	6001809	SCREW, FOR 6022801	1	
10	6001810	SLIDE BLOCK ADJUSTING	1	
11	6001811	LOCK BOLT FOR 6001813	2	
12	6001416	WASHER, FOR 6001813	1	
13	6001813	STUD SLIDE BLOCK ADJUSTING SUPPORT	2	
14	6001814	LOCK NUT, FOR 6001813	2	
15	6022802	THROAT PLATE FOR TWO THREAD	1	
16	6001007	SCREW	3	
17	6001817	BALL	1	
18	6001818	BOLT, FOR 6001817	1	
19	6001819	NUT, FOR 6001817	1	
20	6001820	WASHER, FOR 6001817	2	
21	6001821	SCREW, FOR 6001823	1	
22	6001416	WASHER, FOR 6001823	1	
23	6001823	KNIFE BRACKET	1	
24	6001824	KNIFE BRACKET PIN	1	
25	6001825	BUSHING, FOR 6001824	1	
26	6001826	KNIFE TENSION SPRING	1	
27	6001222	SCREW, FOR 6001825	1	
28	6001828	KNIFE MOVING	1	
29	6001829	SCREW, FOR 6001828	2	
30	6001830	KNIFE STATIONARY	1	
31	6001829	SCREW, FOR 6001830	2	
32	6001832	SPRING LOCK WASHER	1	
33	6001008	THREAD EYELET	1	

(11) MN600A, MN602A PARTS

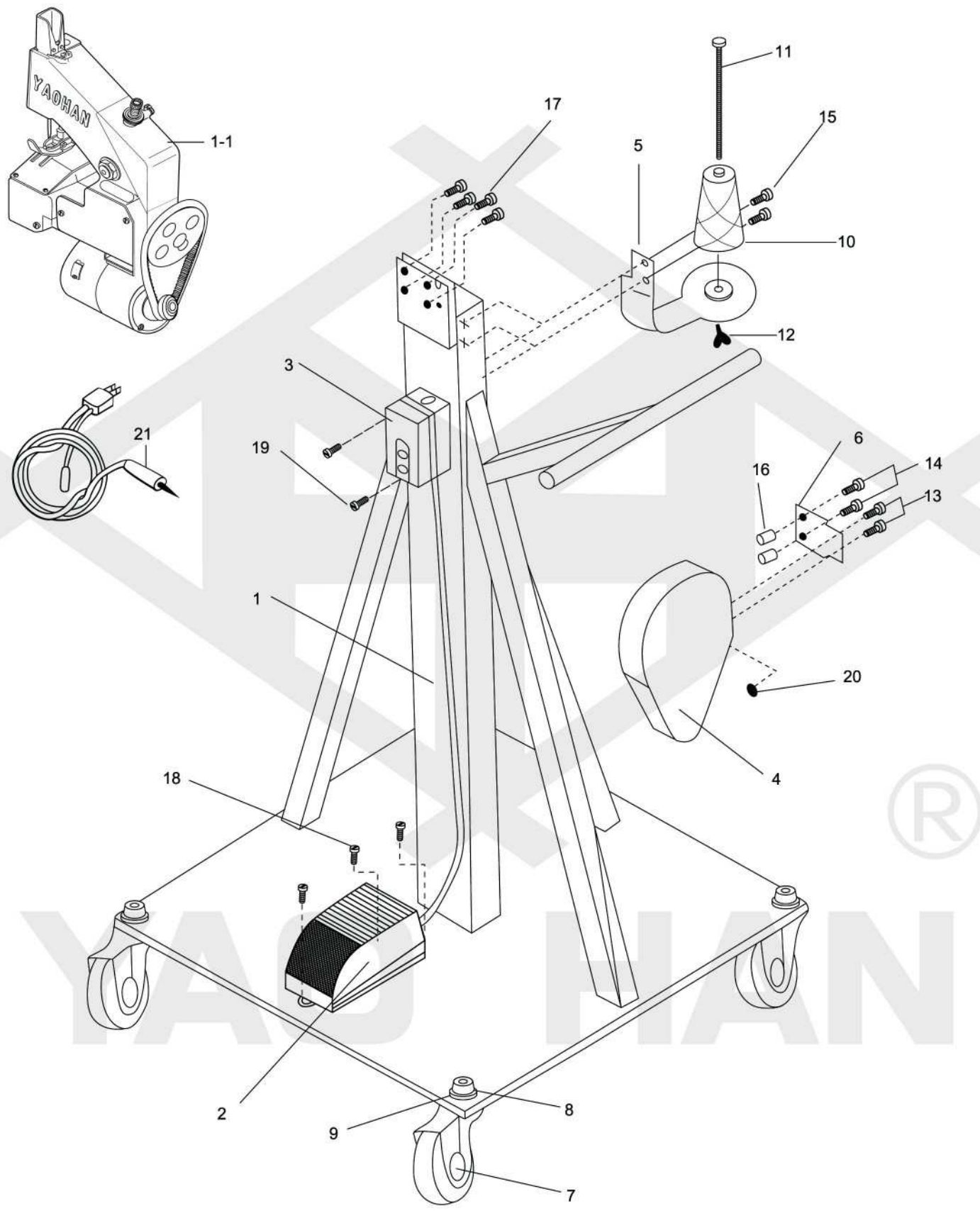

(11) MN600A, MN602A PARTS

ITEM	PART NO.	DESCRIPTION	Q'ty	REMARKS
1	MN6003001	MOVED FRAME	1	
1-1	MN6003001-1	BAG CLOSER MACHINE FOR MN600A-110V	1	
	MN6003001-2	BAG CLOSER MACHINE FOR MN600A-220V		
	MN6003001-3	BAG CLOSER MACHINE FOR MN600A-240V		
	MN6003001-4	BAG CLOSER MACHINE FOR MN602A-110V		
	MN6003001-5	BAG CLOSER MACHINE FOR MN602A-220V		
	MN6003001-6	BAG CLOSER MACHINE FOR MN602A-240V		
2	MN6003002	FOOT PEDAL	1	
3	MN6003003	PUSH BUTTON SWITCH	1	
4	MN6003004	BELT COVER	1	
5	6001001	THREAD STAND	1	
6	MN6003006	FIXED PLATE	1	
7	MN6003007	RUBBER WHEEL	4	
8	MN6003008	NUT	8	
9	MN6003009	WASHER	4	
10	6001005	THREAD	1	
11	6001004	BOLT THREAD CLAMPING	1	
12	6001003	NUT WING 1/4"-20N.C.	1	
13	MN6003013	SCREW	2	
14	6001212	SCREW	2	
15	6001002	SCREW	2	
16	MN6003016	BUSHING	2	
17	6001212	SCREW	4	
18	6001402	SCREW	3	
19	6001402	SCREW	2	
20	MN6003020	NUT	2	
21	6002001	CORD, SET FOR 110V	1	
	6002001-1	CORD,SET FOR"CE"		
	6002001-2	CORD,SET FOR 220V, 240V		

(12) PARTS FOR FN600A FN602A

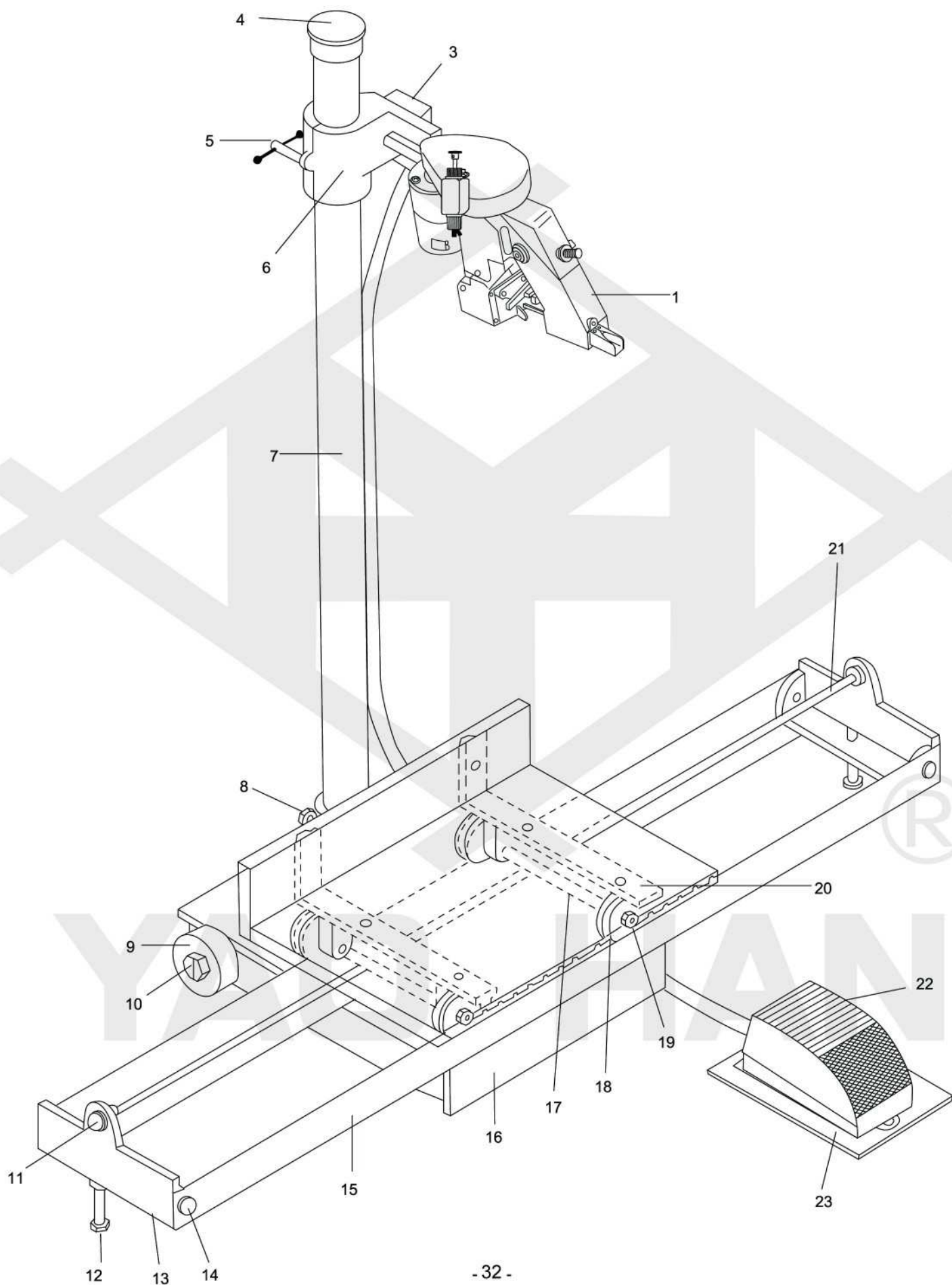

(12) PARTS FOR FN600A FN602A

ITEM	PART NO.	DESCRIPTION	Q'ty	REMARKS
1	FN6003201	BAG CLOSER MACHINE FOR FN600A-110V		
	FN6003201-1	BAG CLOSER MACHINE FOR FN600A-220V		
	FN6003201-2	BAG CLOSER MACHINE FOR FN600A-240V		
	FN6003201-3	BAG CLOSER MACHINE FOR FN602A-110V		
	FN6003201-4	BAG CLOSER MACHINE FOR FN602A-220V		
	FN6003201-5	BAG CLOSER MACHINE FOR FN602A-240V		
2	FN6003202	BELT COVER		
3	FN6003203	PUSH BOTTON SWITCH		
4	FN6003204	PLASTIC CAP		
5	FN6003205	HANDLE		
6	FN6003206	ADJUSTABLE CRANK SET		
7	FN6003207	MAIN SHAFT		
8	FN6003208	SCREW		
9	FN6003209	STEEL WHEEL		
10	FN6003210	BOLT		
11	FN6003211	NUT		
12	FN6003212	SCREW		
13	FN6003213	FRAME SET		
14	FN6003214	SCREW		
15	FN6003215	SLIDE FRAME SET		
16	FN6003216	BASE SET		
17	FN6003217	SCREW		
18	FN6003218	SLIDE WHEEL		
19	FN6003219	NUT		
20	FN6003220	FIXED SET		
21	FN6003221	SCREW SHAFT		
22	FN6003222	PEDAL SWITCH		
23	FN6003223	PEDAL BASE		

(13) ACCESSORY BAG

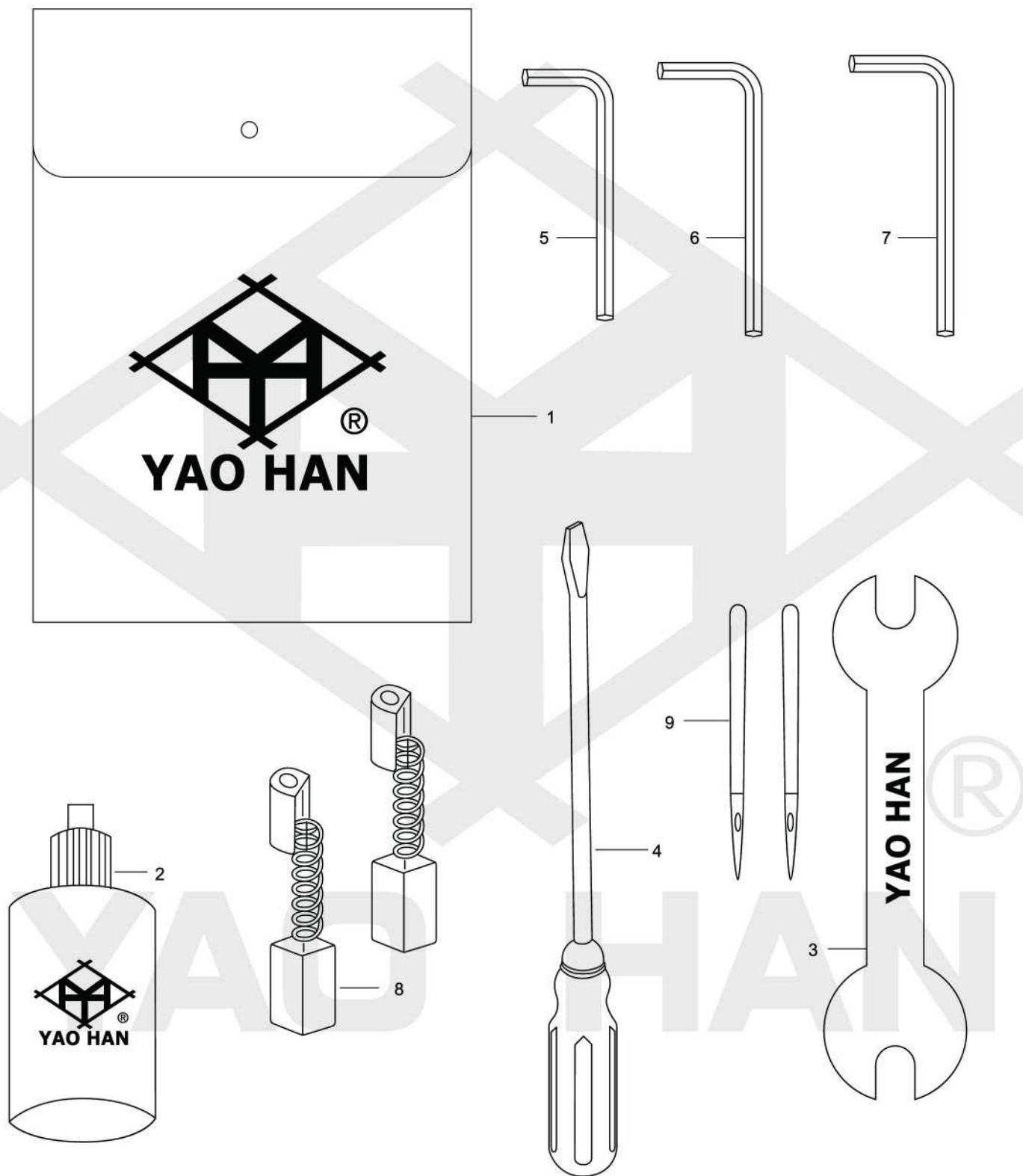

(13) ACCESSORY BAG

ITEM	PART NO.	DESCRIPTION	Q'ty	REMARKS
1	6003401	ACCESSORY BAG	1	
2	6003402	OILER	1	
3	6003403	SPANNER	1	
4	6003404	SCREW DRIVER	1	
5	6003405	HEX WRENCH 2.0 MM	1	
6	6003406	HEX WRENCH 2.5 MM	1	
7	6003407	HEX WRENCH 3.0 MM	1	
8	6002007	CARBON BRUSH FOR AC MOTOR (SIZE:6 X 8 X 15)	2	
	6002008	CARBON BRUSH, FOR DC MOTOR 12V/24V (SIZE:6X8X15)		
9	6001433	NEEDLE (DNX1 #25)	2	

(14) MOTOR PARTS

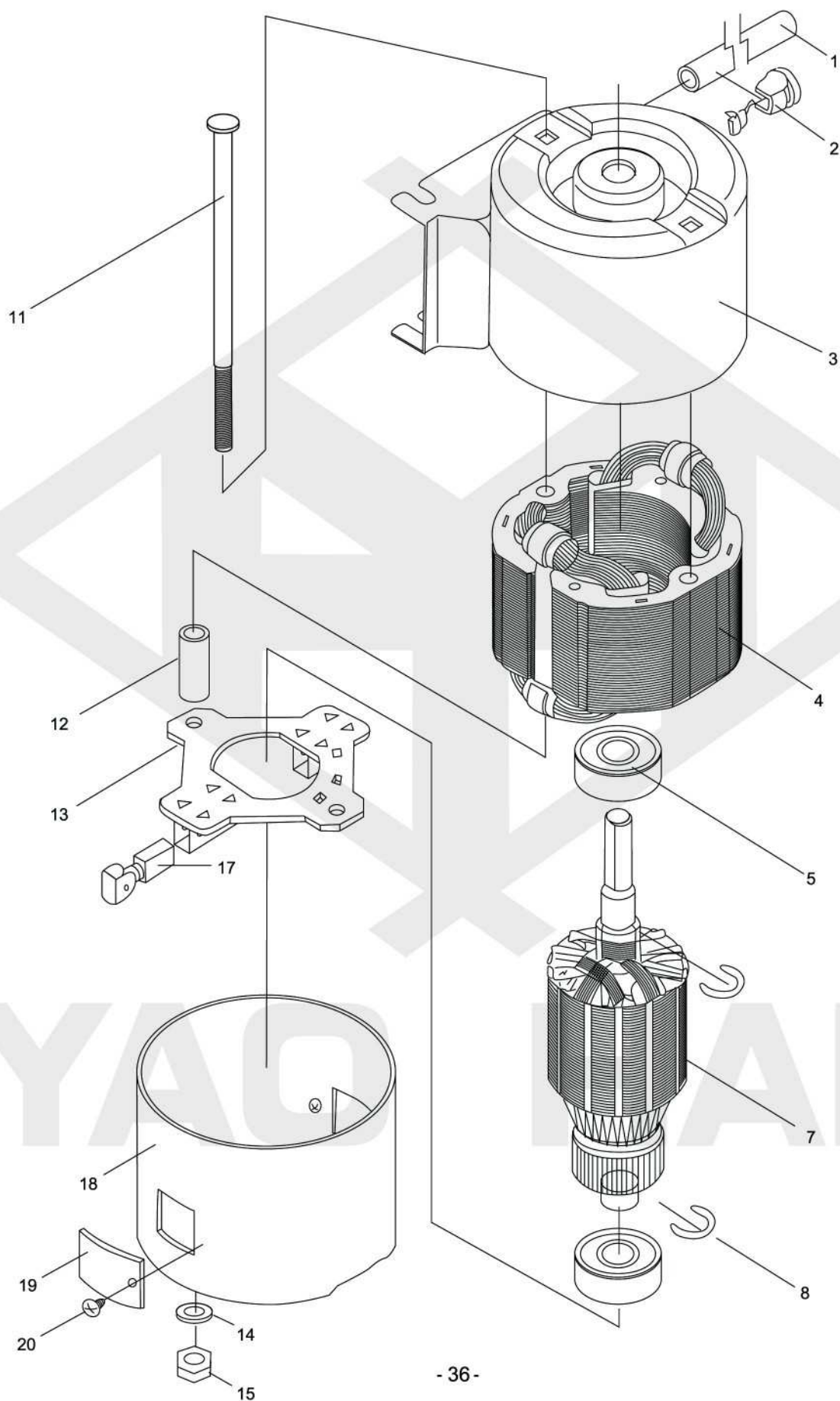

(14) MOTOR PARTS

ITEM	PART NO.	DESCRIPTION	Q'ty	REMARKS
1	6003601	CORD		電線
2	6003602	STRAIN RELIFE BUSHINGS		絕緣套
3	6003603	CASE A		馬達殼
4	6003604	STATOR ASSY FOR 110V		馬達線
	6003604-1	STATOR ASSY FOR 220V		馬達線
	6003604-2	STATOR ASSY FOR 240V		馬達線
	6003604-3	STATOR ASSY FOR 12V		馬達線
	6003604-4	STATOR ASSY FOR 24V		馬達線
5	6003605	BALL BEARING		滾珠軸承
7	6003607	ARMATURE ASSY FOR 110V		馬達轉子
	6003607-1	ARMATURE ASSY FOR 220V		馬達轉子
	6003607-2	ARMATURE ASSY FOR 240V		馬達轉子
	6003607-3	ARMATURE ASSY FOR 12V		馬達轉子
	6003607-4	ARMATURE ASSY FOR 24V		馬達轉子
8	6003608	C RING		C型扣環
10	6003610	BRACKET		螺絲
11	6003611	SCREW		導管
12	6003612	PIPE		PC基板
13	6003613	PC PLATE		華司
14	6003614	WASHER		螺帽
15	6003615	NUT		碳刷
17	6002007	CARBON BRUSH FOR AC MOTOR		碳刷
	6002008	CARBON BRUSH FOR DC MOTOR		馬達殼B
18	6003618	CASE B		碳刷蓋
19	6002009	CAP FOR MOTOR		螺絲
20	6002010	SCREW		